

LOOSE TUBE CABLE

Multi-Tube Armored/Dielectric Cable

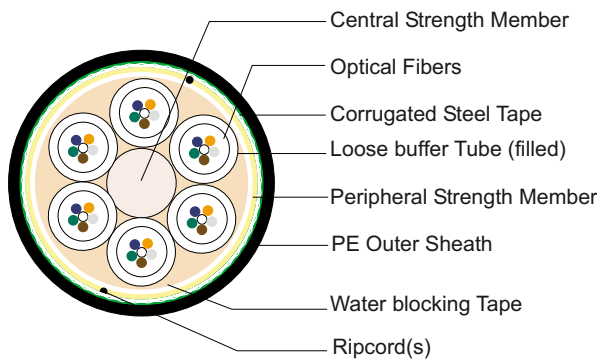
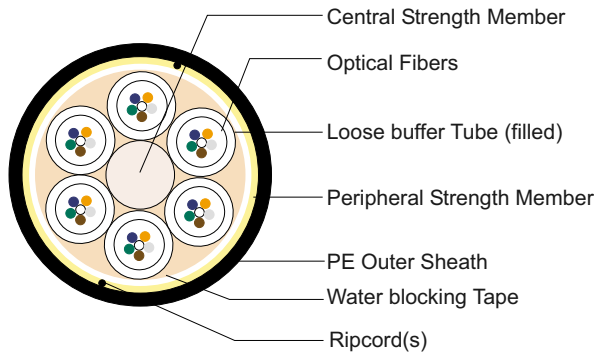

Suitable for aerial, duct or direct buried applications, Loose Tube cables are the most widely used cables today. Teracom Loose Tube cables are available in a wide variety of standard and customized configurations. Standard configurations are dielectric or armored with a single or dual jacket design.

Teracom Cables are constructed with highest quality optical fibers from internationally reputed manufacturers and the cable manufacturing is done under strict quality assurance system adhering to **ISO 9001** Quality System.

Features	Benefits
▶ Lightweight	Ease of Installation.
▶ Rugged Design	Environmental Stability.
▶ High Density Polyethylene Sheath	Excellent resistance of cracking abrasion during blown or pulled installation.
▶ Fibers in individual buffer Tubes	Ease of installation, identification and routing.
▶ Designed for duct, lashed aerial or direct buried installations.	Ease of Installation.
▶ Central Strength Memer (CSM)	Provides tensile strength as well as buckling resistance

Specifications	
▶ Maximum Tensile Loading	2700 N
▶ Maximum recommended Service Load.	900 N
▶ Environmental Temperature .	
-Installation	-30° C to +60° C .
-Operating	-40° C to +70° C
-Storage	-50° C to +75° C
▶ Compression Resistance	220N/ cm
▶ Compound Flow Temperature	< 80° C

Teracom Private Limited
 Plot No. 250, Kundaim Industrial Estate, Kundaim, Goa 403 115 INDIA
 Tel : +91 832 239 5631, 239 6165, 66; Fax : +91 832 564 3189
 Email: sales@teracomfiber.com

Fiber Count	# of Tubes	# of Fibers / Tube	Max # of Tubes and Filler Rods	Cable Outside Diameter (Dielectric)	Cable Weight Kg/Km (Dielectric)	Cable Outside Diameter (Armored)	Cable Weight Kg/Km (Dielectric)
6	1	6	5	11.0	120	13.5	180
12	2	6	5	11.0	120	13.5	180
18	3	6	5	11.0	120	13.5	180
24	2	12	5	11.0	120	13.5	180
36	3	12	5	11.0	120	13.5	180
48	4	12	5	11.0	120	13.5	180
72	6	12	6	12.5	135	15	210
96	8	12	8	14	170	17	260
120	10	12	10	16.5	220	18.5	320
144	12	12	12	17.7	270	20	380
216	9	24	9	19.3	300	20.8	410
288	12	24	12	23.2	360	24.8	500

Ordering Information

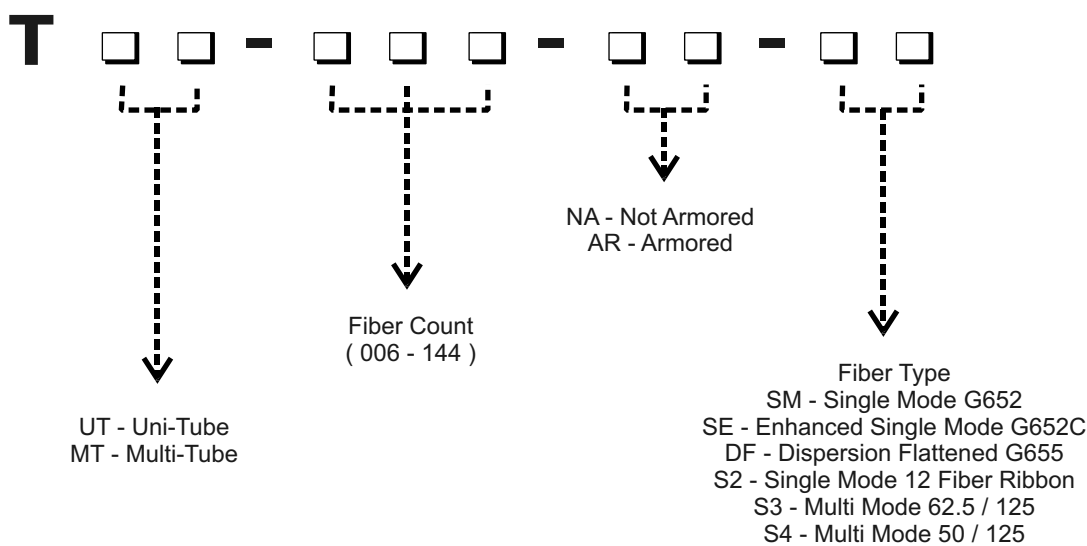

Teracom Private Limited
 Plot No. 250, Kundaim Industrial Estate, Kundaim, Goa 403 115 INDIA
 Tel : +91 832 239 5631, 239 6165, 66; Fax : +91 832 564 3189
 Email: sales@teracomfiber.com